

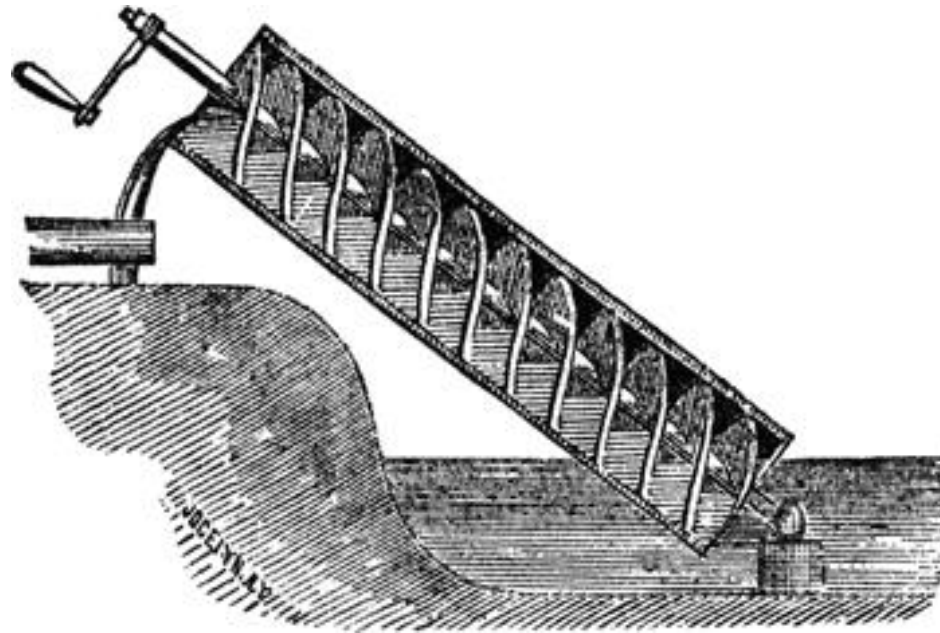

The History and Future of Fluid Power Pumps and Motors

Samuel Kärnell, Linköping University



≈ 2000 B.C.

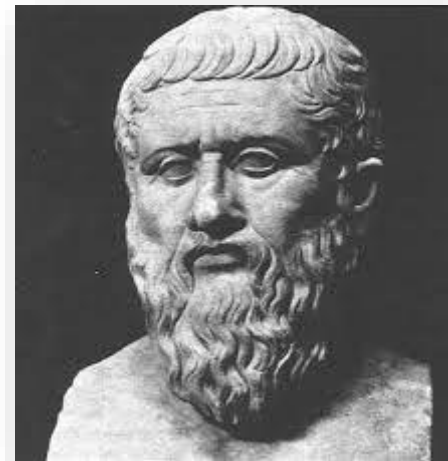
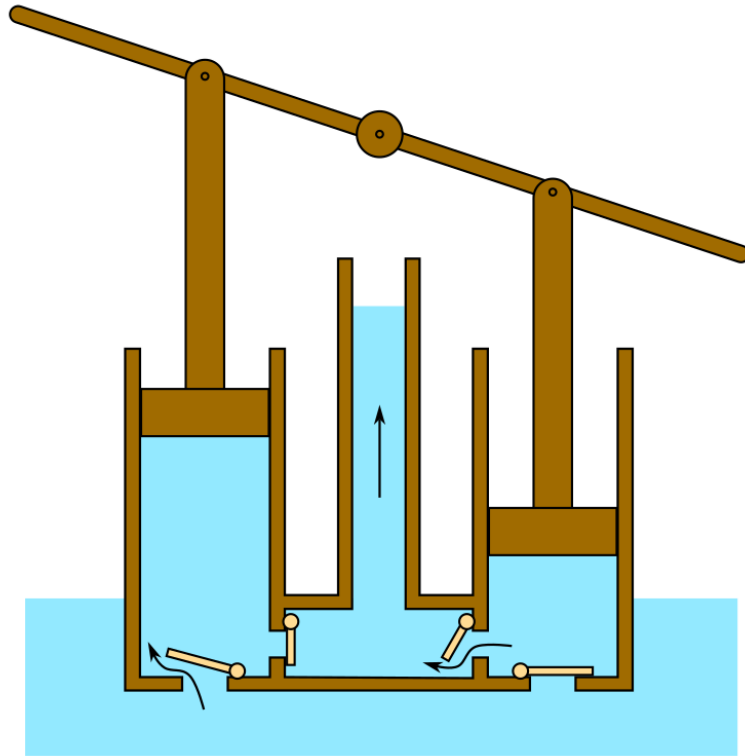

Ctesibius of Alexandria,
≈ 250 B.C.

Fast forward...

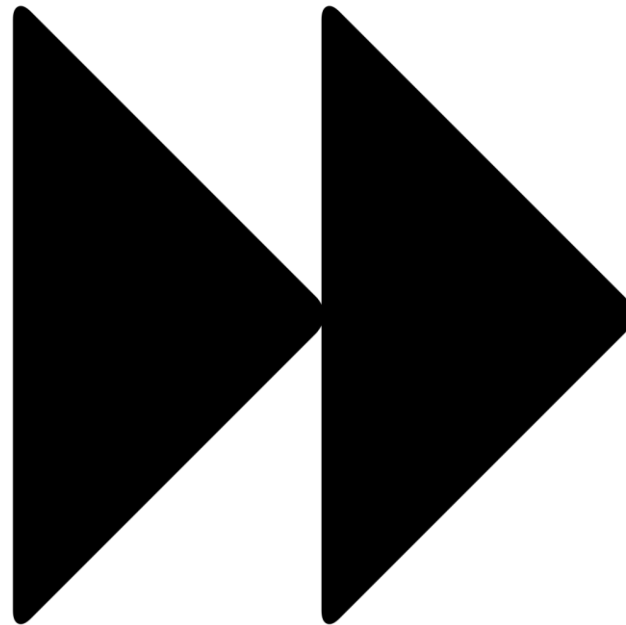

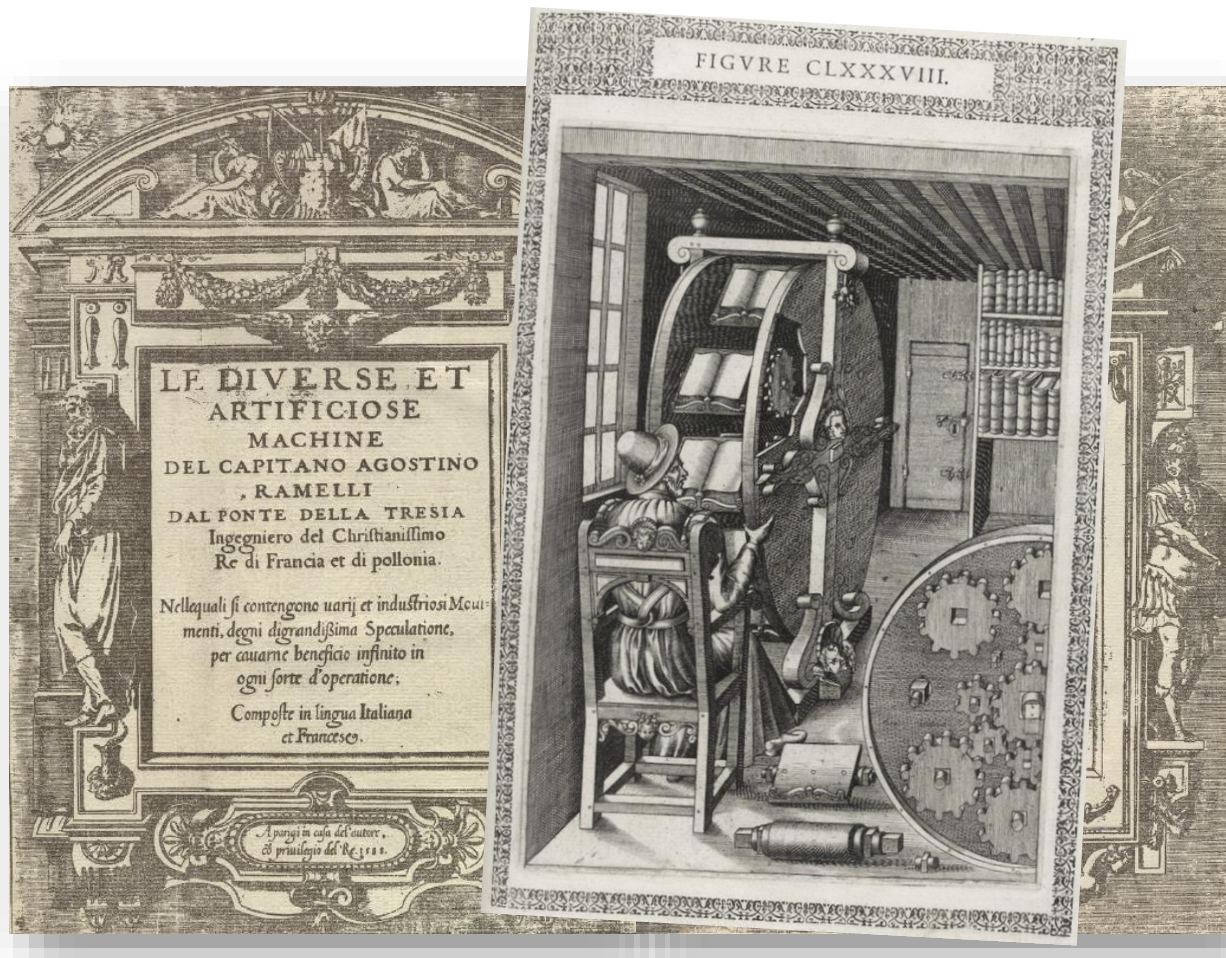

Agostino Ramelli, 1588

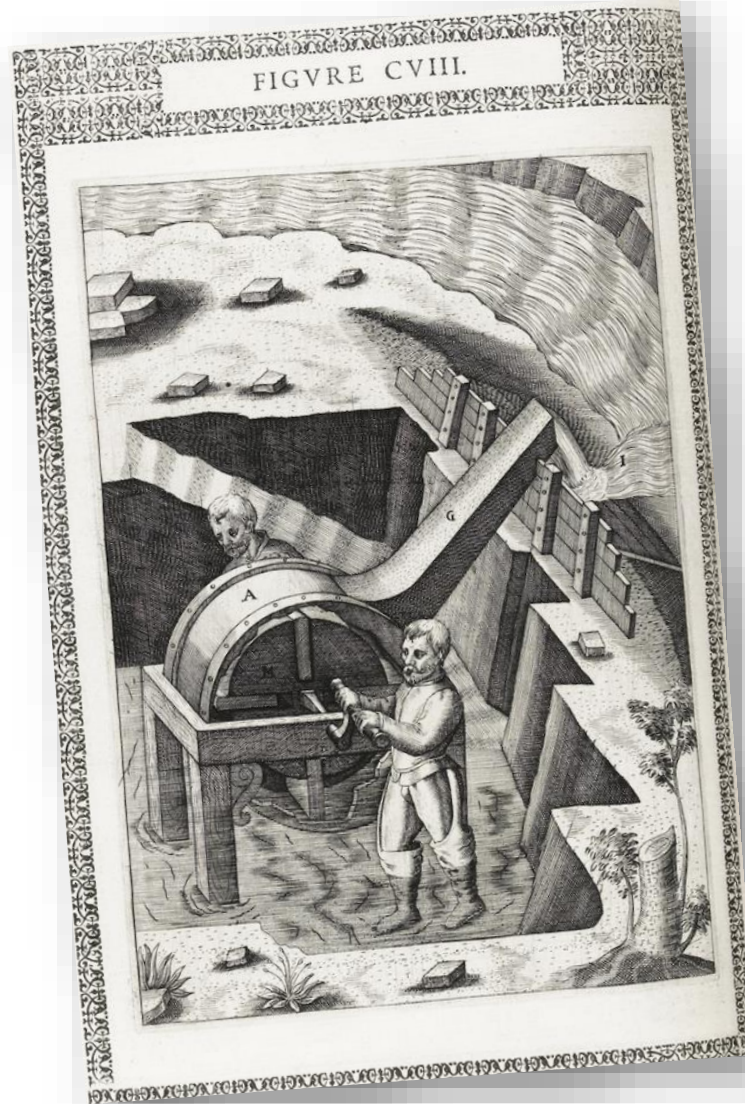

Agostino Ramelli, 1588

Axial piston pumps

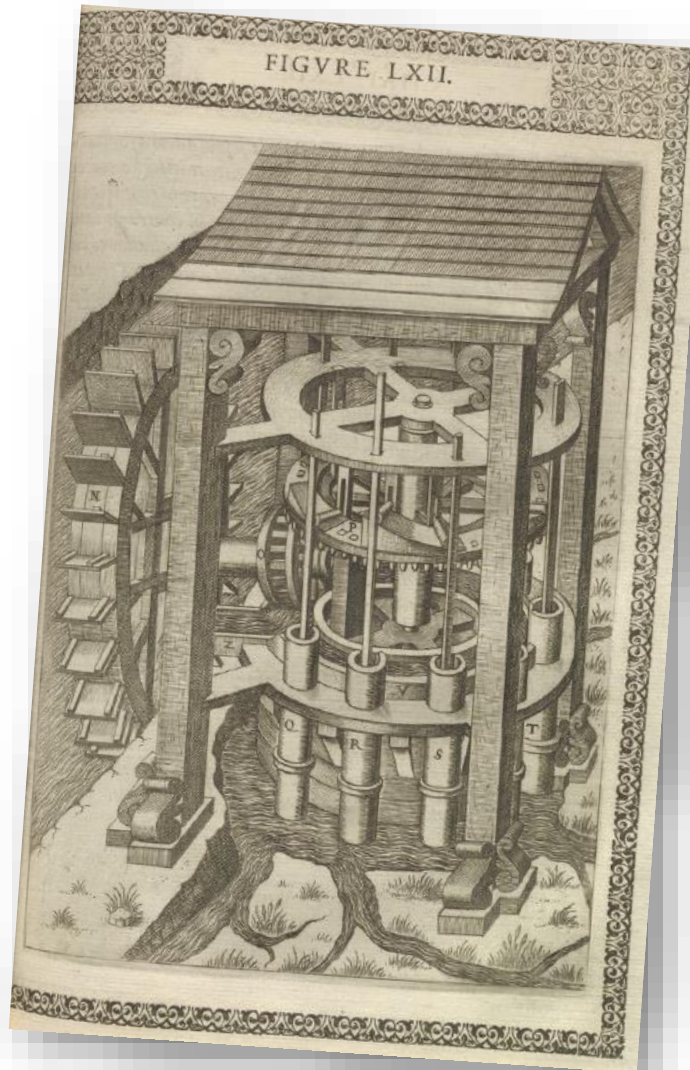

Agostino Ramelli, 1588

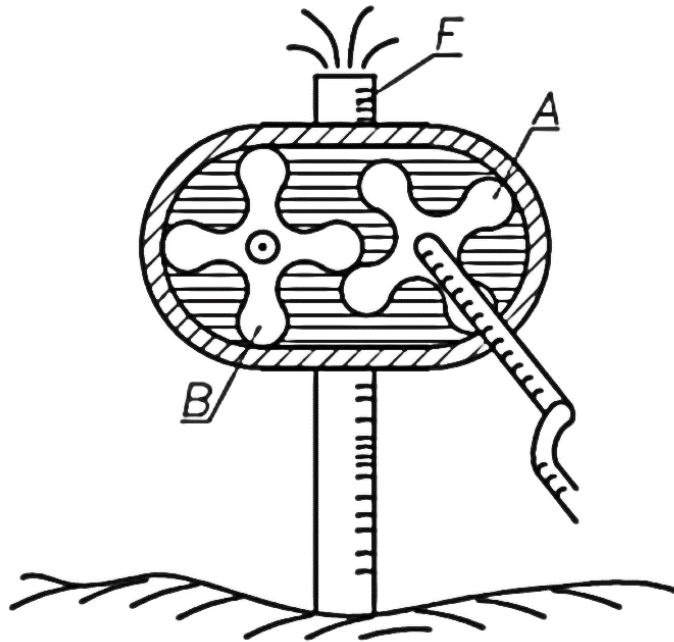

Johannes Kepler, ≈1600



Blaise Pascal,
≈1650



Joseph Bramah, 1795

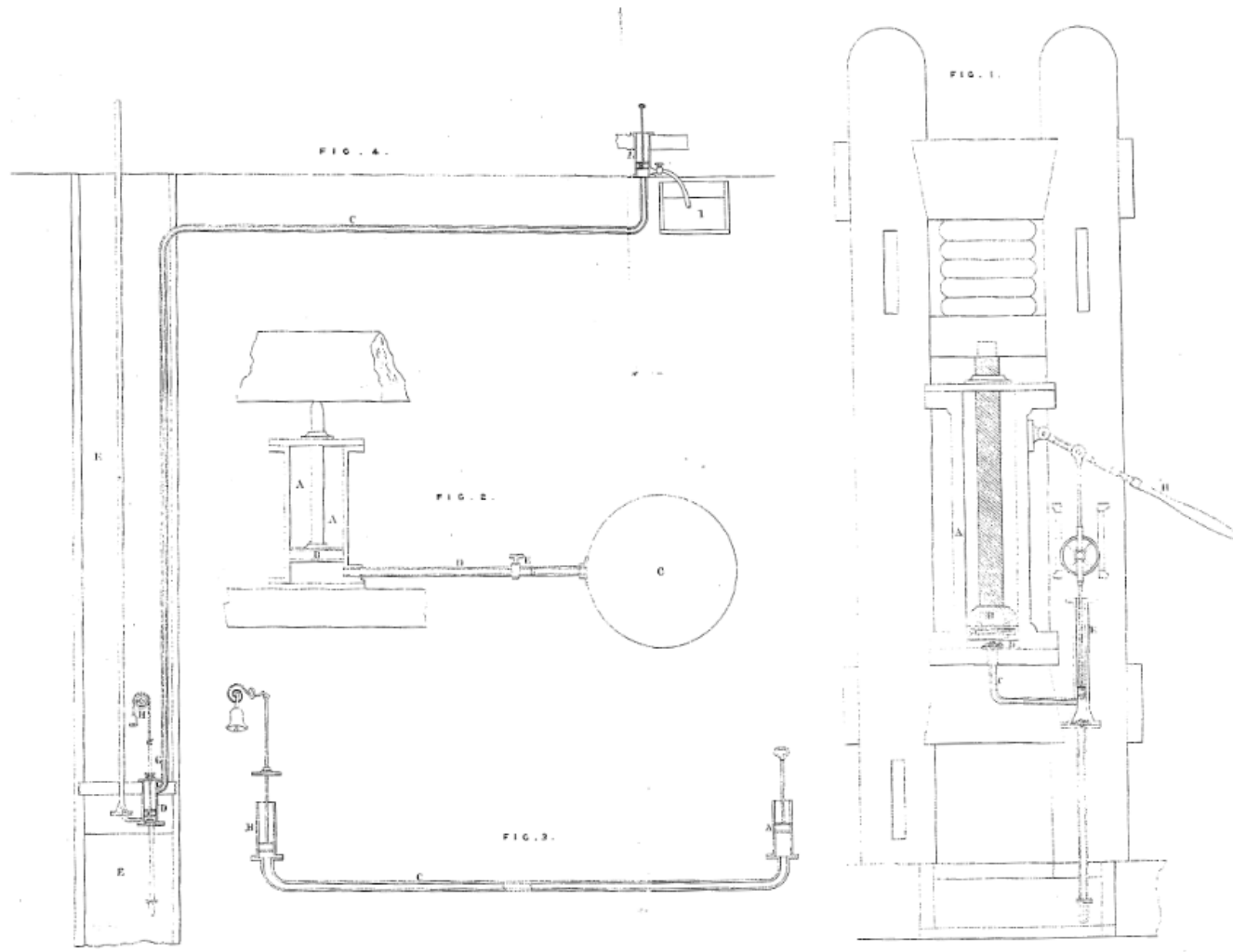

Oscillating piston motor (“water engine”)

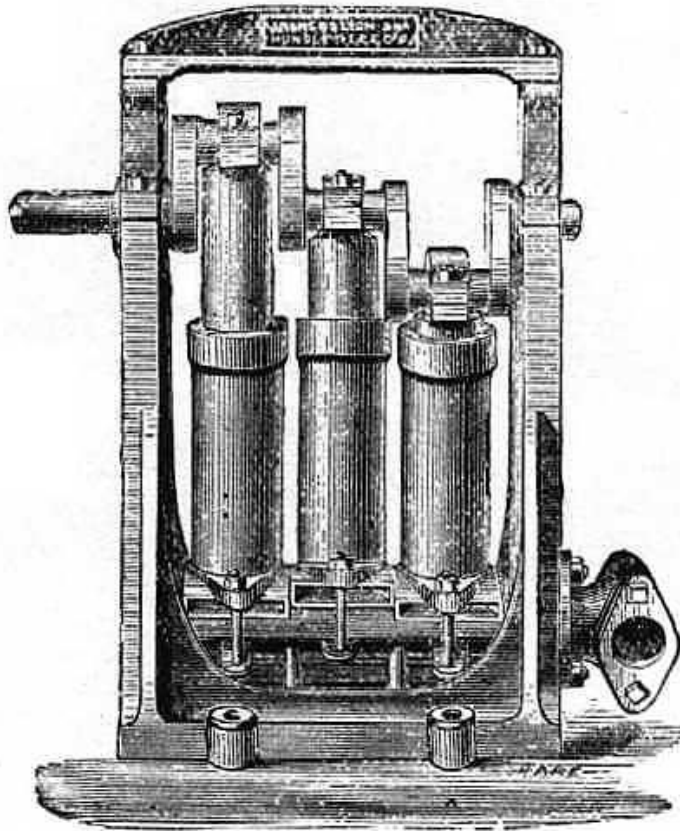

From *The Hydraulic Age* by B. Pugh, pub Mechanical Engineering Publications Ltd, 1980

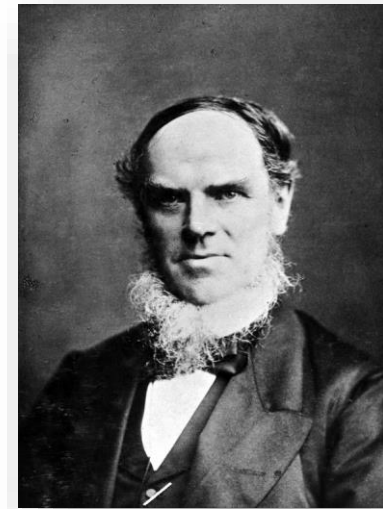

John Ramsbottom, ≈ 1840

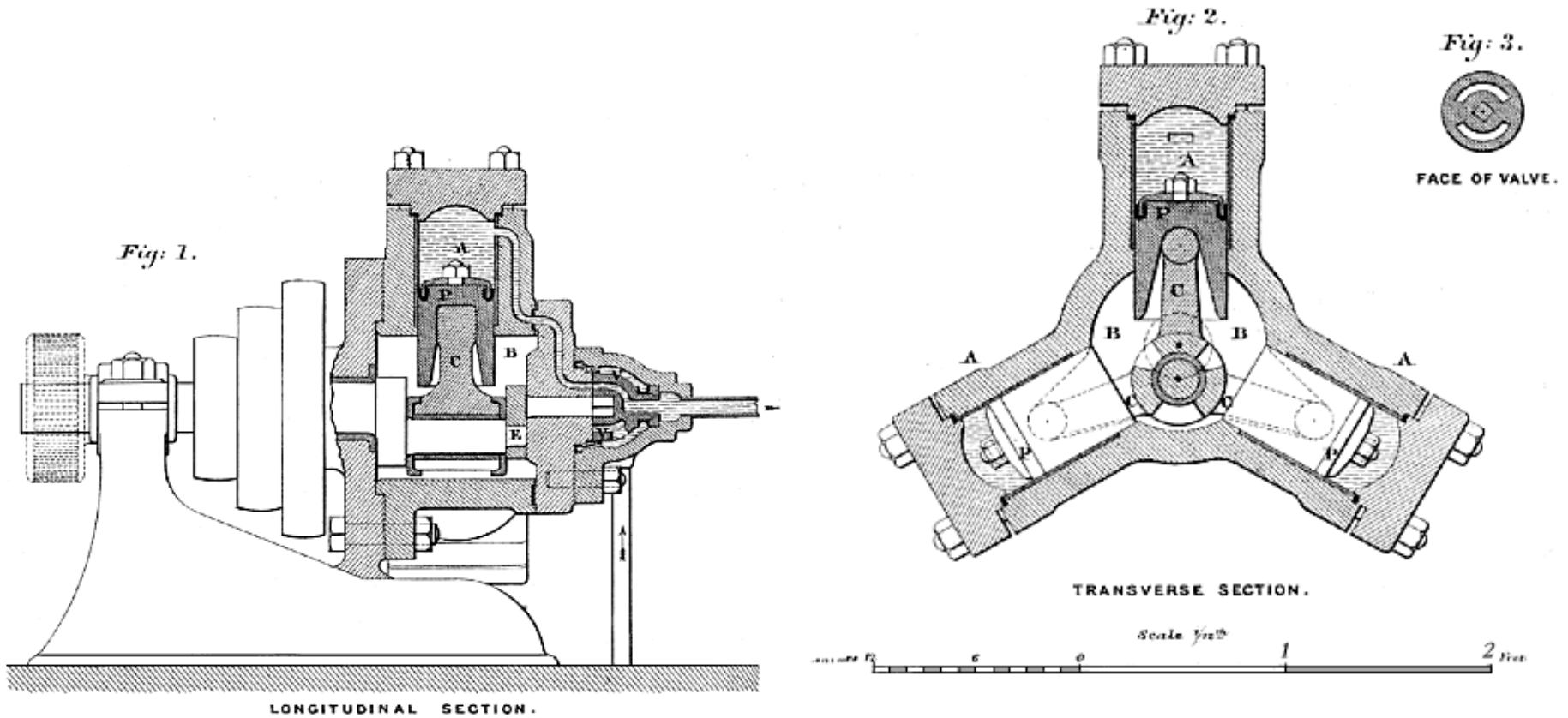

From *Hydraulic Power & Machinery* by Henry Robinson. Pub Charles Griffin & Co, London 1893

Peter Brotherhood, 1870s

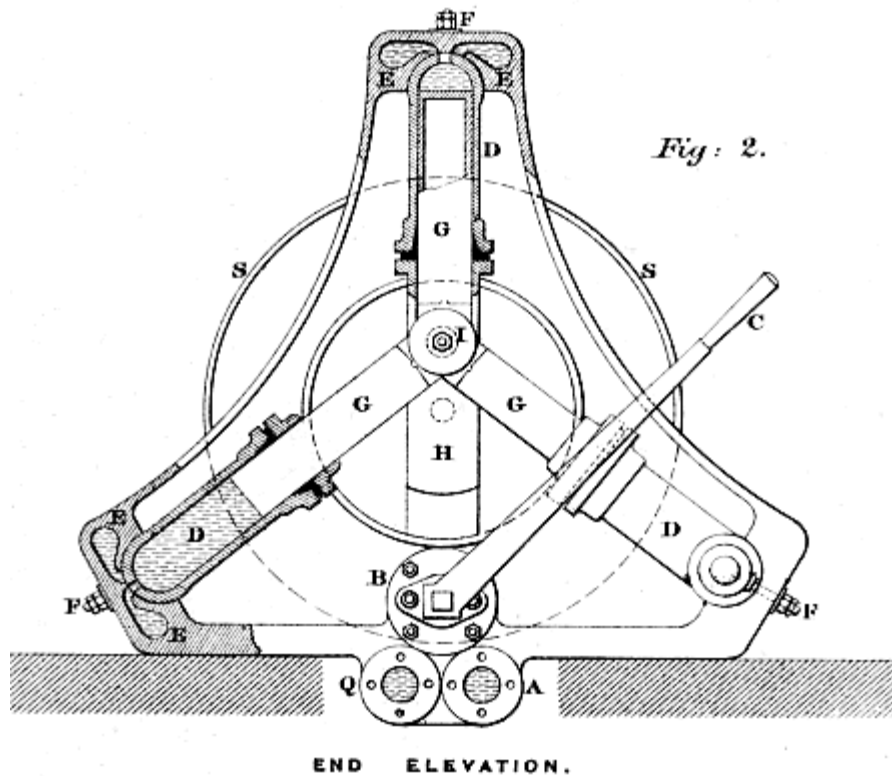

From *Hydraulic Power & Machinery* by Henry Robinson.
Pub Charles Griffin & Co, London 1893

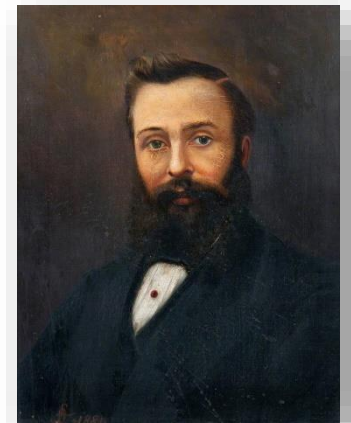

John Hastie, 1870s

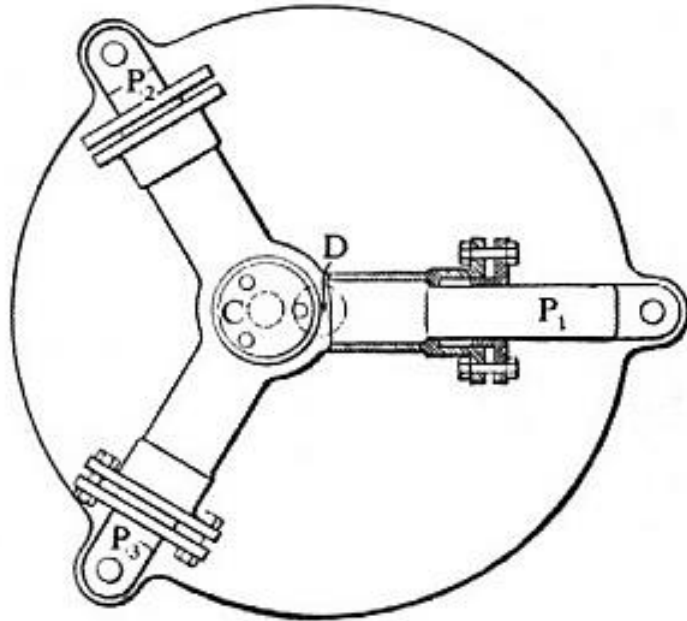

From *Hydraulic Power & Machinery* by Henry Robinson.
Pub Charles Griffin & Co, London 1893

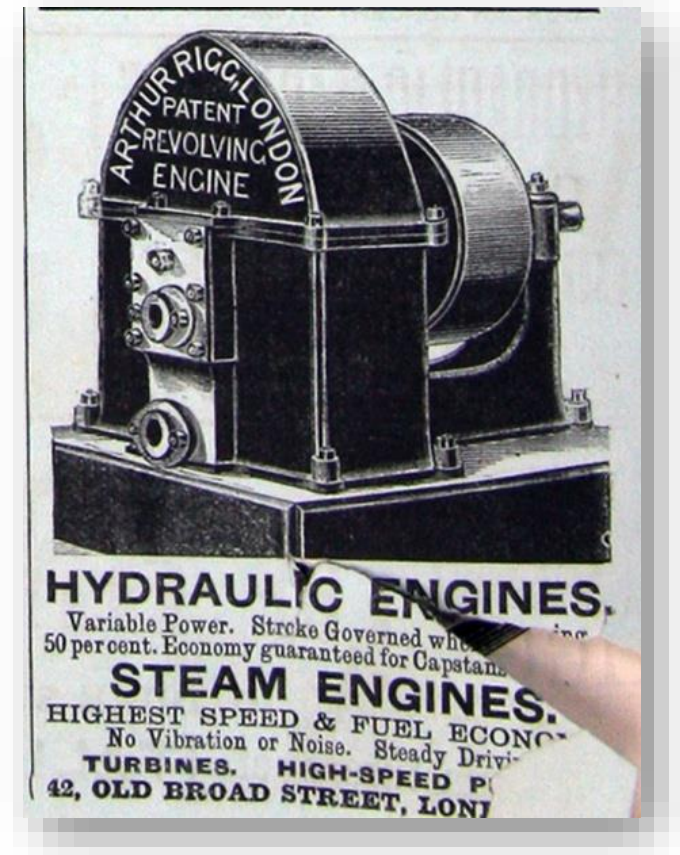

Arthur Rigg, 1880s

“... especially adapted for use with electric motors or other constant rotary power”

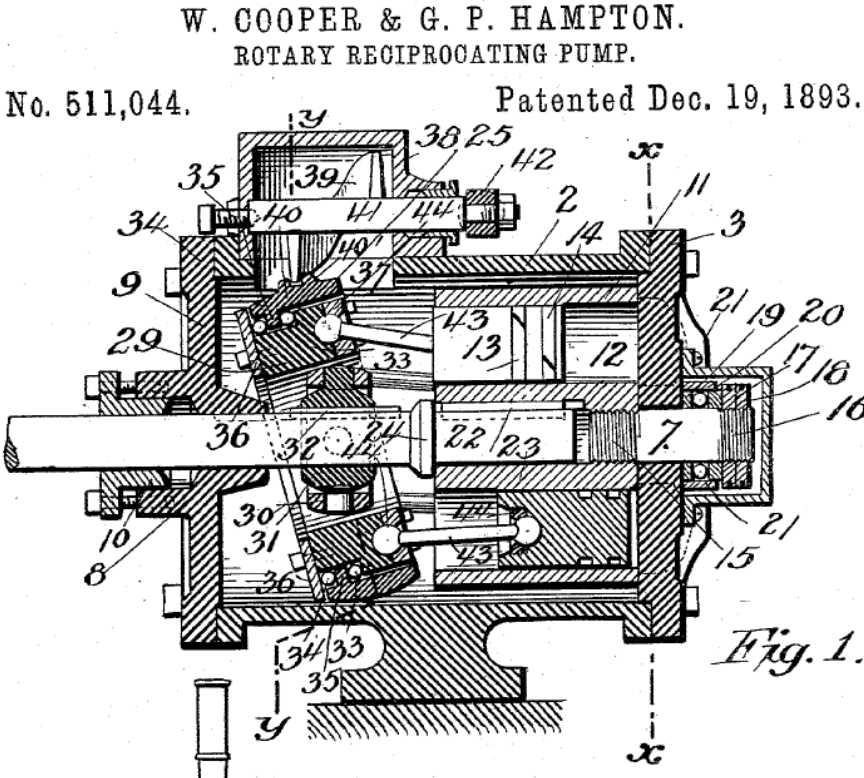

William Cooper and George Hampton, 1893

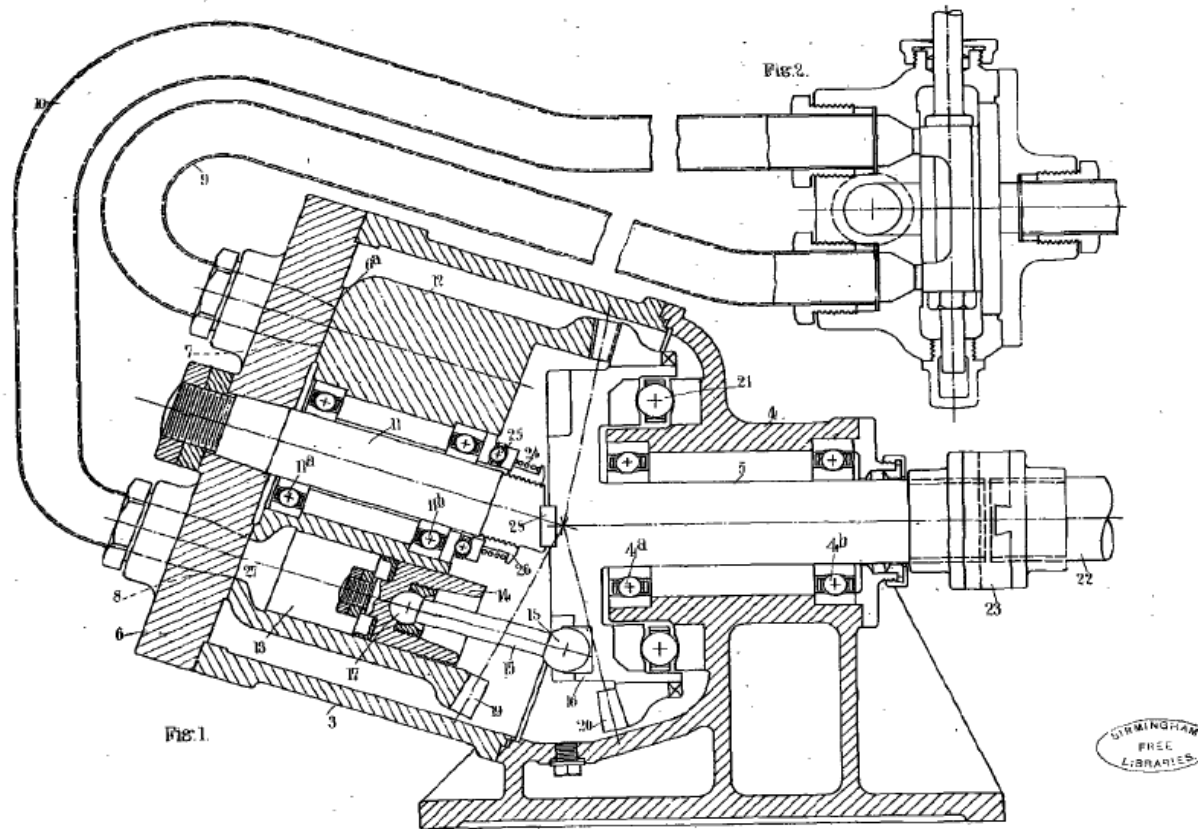

F. H. Clergue, 1908

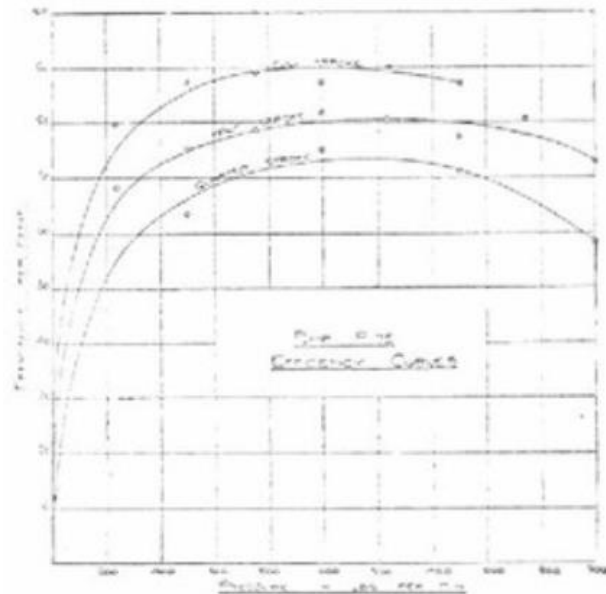
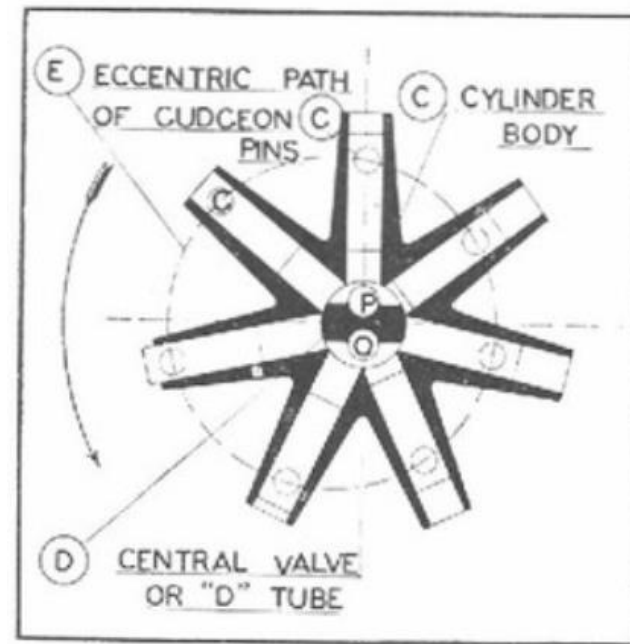
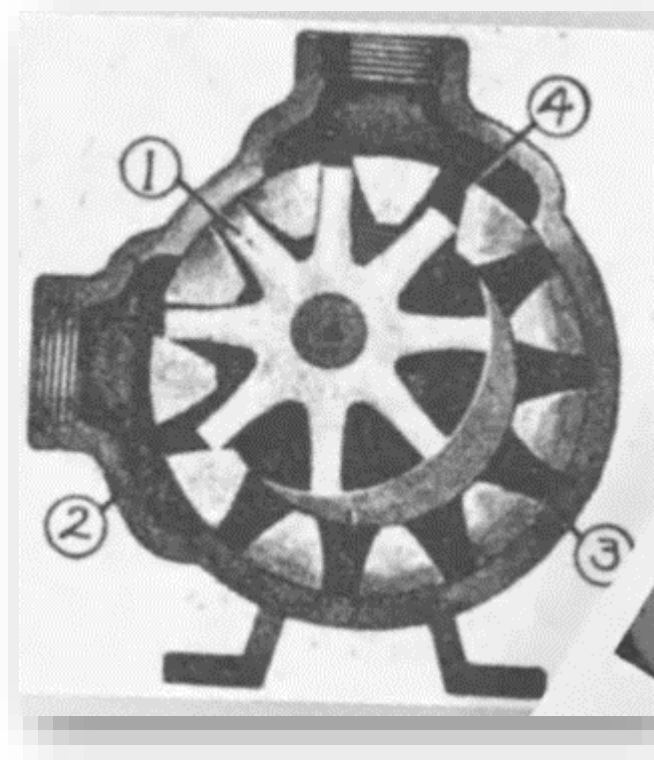

Fig. 5.—Efficiency curves for latest Hele-Shaw pump.



Henry Selby Hele-Shaw, ≈1910



J. Nielsen, ≈1910

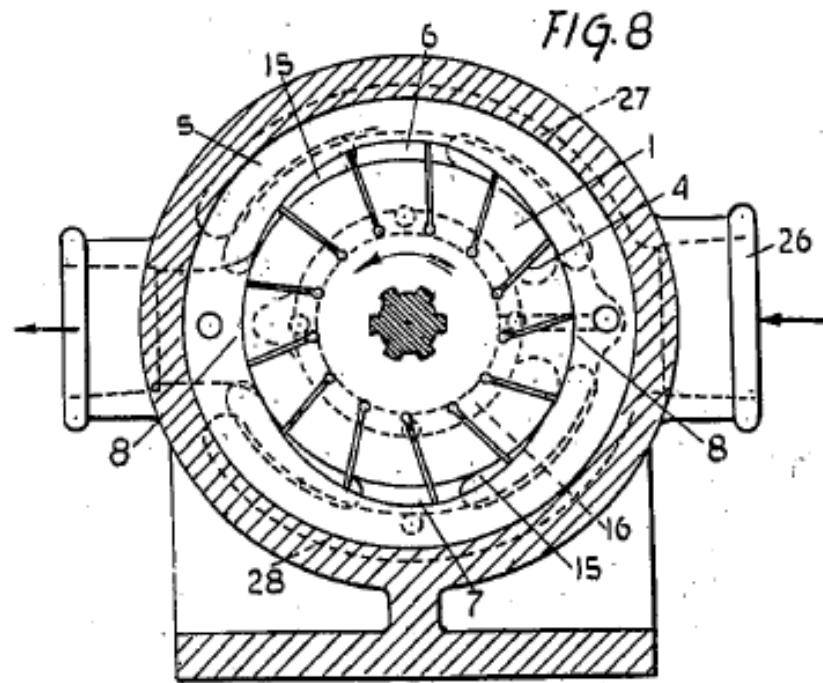

H. Vickers, 1920s

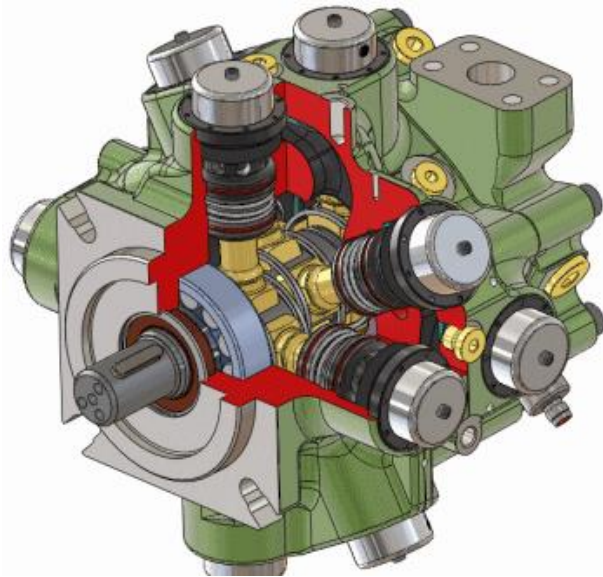

W. Rampen & S. Salter, 1990



Danfoss completes takeover of Scottish firm Artemis Intelligent Power

15 Jan 2021

Danish multi-national Danfoss today [DATE] announced the full purchase of Edinburgh R&D firm Artemis Intelligent Power Ltd – with plans to roll out its innovative Digital Displacement® technology worldwide.

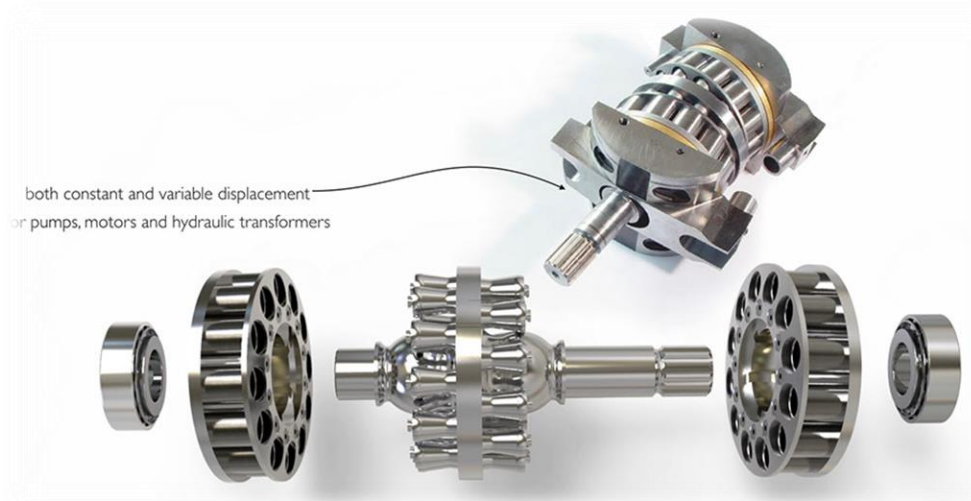

P. Achten, 2000s

BUCHER
hydraulics

Fixed Displacement Piston Pumps and Motors

AX Series



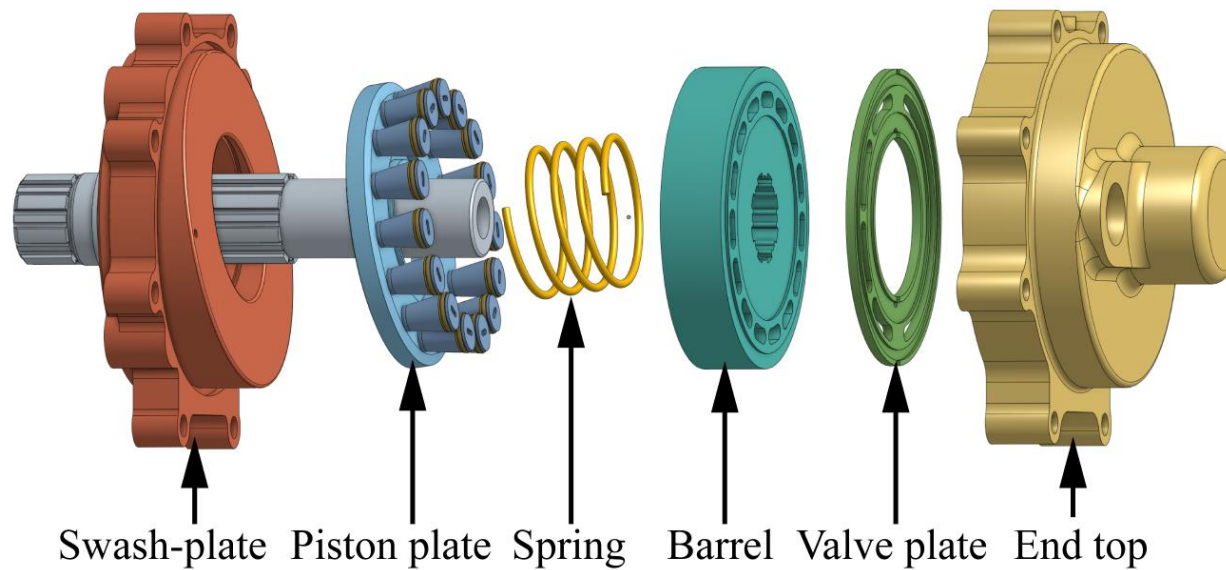

*From A Novel Axial Piston Pump/Motor Principle with Floating Pistons
Design And Testing by Liselott Ericson & Jonas Forssell. 2018*

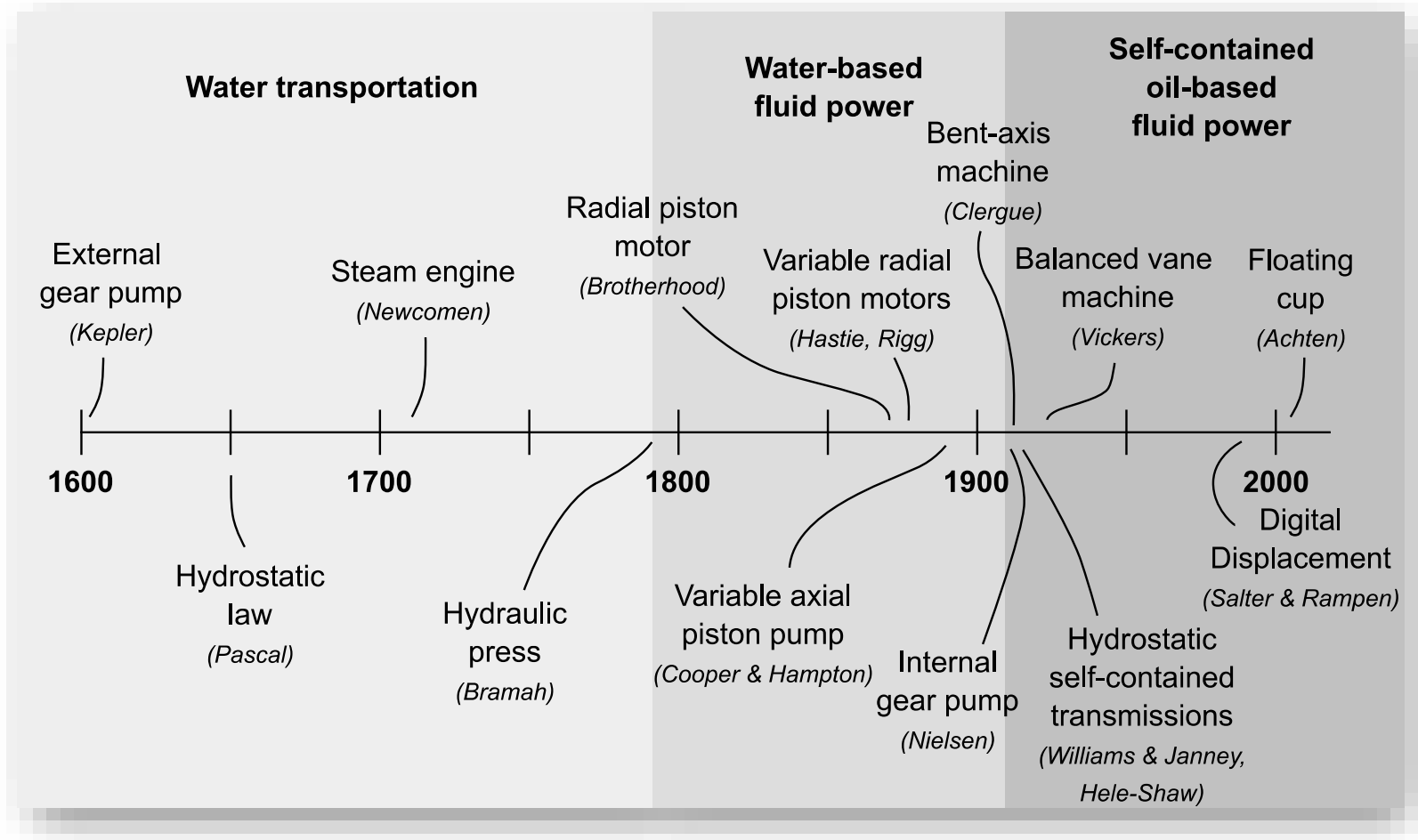

What about the (electrified) future?

Electric machines

- They can run in both directions.
- They can be controlled down to zero speed.
- They can transfer power in both directions.

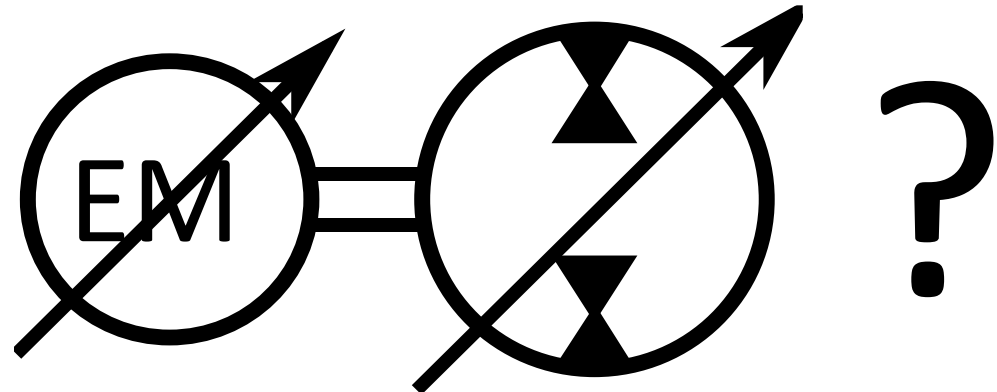

What about the future?

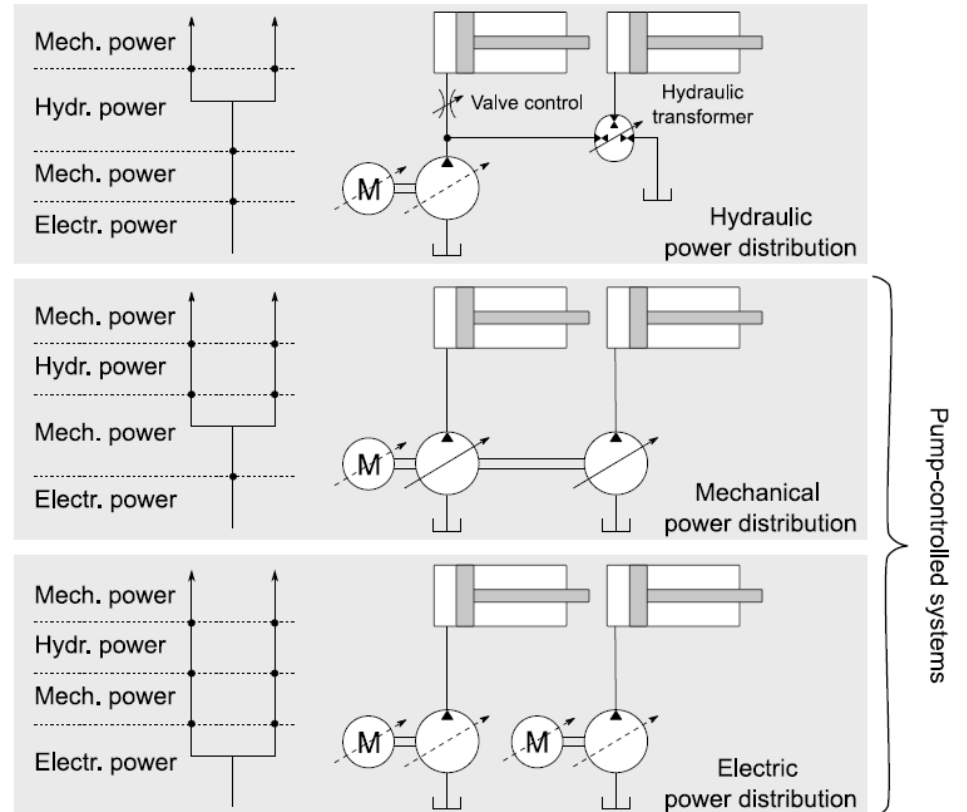
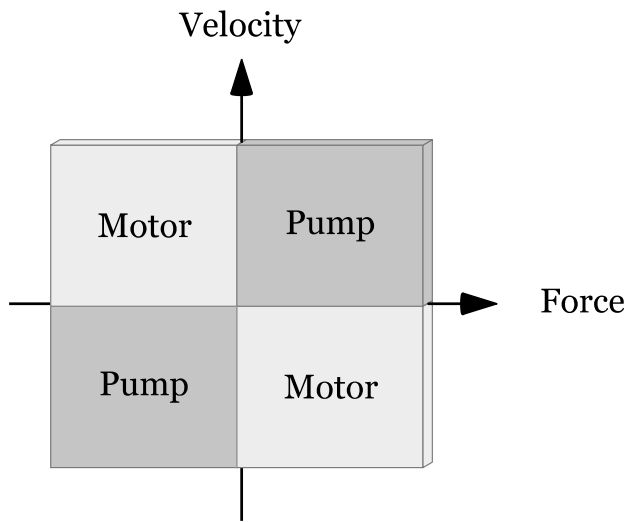



The History and Future of Fluid Power Pumps and Motors

Samuel Kärnell, Linköping University

samuel.karnell@liu.se